

Cast Iron 2-Bolt Flange Units

Set Screw Type - Normal Duty

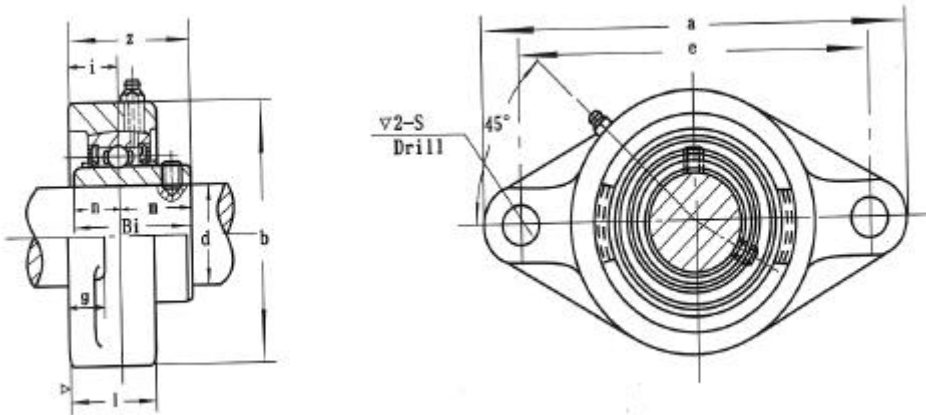

Unit No.	Shaft Dia.		Dimensions (mm/inch)										Bolt Used		Bearing No.	Housing No.	Weight						
	mm	inch	a	e	i	g	l	s	b	Z	Bi	n	m	(mm)			(in.)	kg	Lbs				
UCFL 201	12																						
UCFL 201-8		1/2																					
UCFL 202	15																						
UCFL 202-10		5/8	4-7/16	3-35/64	19/32	7/16	1	15/32	2-3/8	1-5/16	1.2205	0.5000	0.7205	10	3/8		UC 202-10	FL 204	0.5	1.1			
UCFL 203	17		113	90	15	11	25.5	12	60	33.3	31.0	12.7	18.3				UC 203						
UCFL 204-12		3/4															UC 204-12						
UCFL 204	20																UC 204						
UCFL 205-14		7/8															UC 205-14						
UCFL 205-15		15/16	5-1/8	3-57/64	5/8	1/2	1-1/16	5/8	2-11/16	1-13/32	1.3386	0.5630	0.7756	14	1/2		UC 205-15	FL 205	0.7	1.4			
UCFL 205	25		130	99	16	13	27	16	68	35.7	34.0	14.3	19.7				UC 205						
UCFL 205-16		1															UC 205-16						
UCFL 206-18		1-1/8	5-13/16	4-39/64	45/64	1/2	1-7/32	5/8	3-5/32	1-19/32	1.5000	0.6260	0.8740	14	1/2		UC 206-18						
UCFL 206	30		148	117	18	13	31	16	80	40.2	38.1	15.9	22.2				UC 206	FL 206	1	2.2			
UCFL 206-19		1-3/16															UC 206-19						
UCFL 207-20		1-1/4															UC 207-20						
UCFL 207-21		1-5/16															UC 207-21						
UCFL 207-22		1-3/8	6-11/32	5-1/8	3/4	9/16	1-11/32	5/8	3-17/32	1-3/4	1.6890	0.6890	1.0000	14	1/2		UC 207-22	FL 207	1.3	2.8			
UCFL 207	35		161	130	19	14	34	16	90	44.4	42.9	17.5	25.4				UC 207						
UCFL 207-23		1-7/16															UC 207-23						
UCFL 208-24		1-1/2															UC 208-24						
UCFL 208-25		1-9/16	6-7/8	5-43/64	53/64	9/16	1-13/32	5/8	3-15/16	2-1/32	1.9370	0.7480	1.1890	14	1/2		UC 208-25	FL 208	1.7	3.6			
UCFL 208	40		175	144	21	14	36	16	100	51.2	49.2	19.0	30.2				UC 208						
UCFL 209-26		1-5/8															UC 209-26						
UCFL 209-27		1-11/16															UC 209-27						
UCFL 209-28		1-3/4	7-13/32	5-53/64	55/64	19/32	1-1/2	3/4	4-1/14	2-1/16	1.9370	0.7480	1.1890	14	1/2		UC 209-28	FL 209	2	4.3			
UCFL 209	45		188	148	22	15	38	19	108	52.2	49.2	19.0	30.2				UC 209						
UCFL 210-30		1-7/8															UC 210-30						
UCFL 210-31		1-15/16	7-3/4	6-3/16	55/64	19/32	1-9/16	3/4	4-17/32	2-5/32	2.0315	0.7480	1.2835	16	5/8		UC 210-31	FL 210	2.3	5			
UCFL 210	50		197	157	22	15	40	19	115	54.6	51.6	19.0	32.6				UC 210						
UCFL 211-32		2															UC 211-32						
UCFL 211-34		2-1/8	8-13/16	7-1/4	63/64	23/32	1-11/16	3/4	5-1/8	2-5/16	2.1890	0.8740	1.3150	16	5/8		UC 211-34	FL 211	3.3	7.3			
UCFL 211	55		224	184	25	18	43	19	130	58.4	55.6	22.2	33.4				UC 211						
UCFL 211-35		2-3/16															UC 211-35						
UCFL 212-36		2-1/4	9-27/32	7-61/64	1-9/64	23/32	1-7/8	29/32	5-1/2	2-23/32	2.5630	1.0000	1.5630	20	3/4		UC 212-36						
UCFL 212	60		250	202	29	18	48	23	140	68.7	65.1	25.4	39.7				UC 212	FL 212	4.3	9.5			
UCFL 212-38		2-3/8															UC 212-38						
UCFL 212-39		2-7/16															UC 212-39						
UCFL 213-40		2-1/2	10-5/32	8-17/64	1-3/16	25/32	1-31/32	29/32	6-3/32	2-3/4	2.5630	1.0000	1.5630	20	3/4		UC 213-40	FL 213	5.2	11			
UCFL 213	65		258	210	30	20	50	23	155	69.7	65.1	25.4	39.7				UC 213						